

SERPAC 110-I

Electronics Enclosures

NOTES:
1. WHEN MACHINE OR I PLATES MODIFICATIONS ARE REQUIRED,
USE THE CENTER OF THE ENCLOSURE TO DIMENSION.

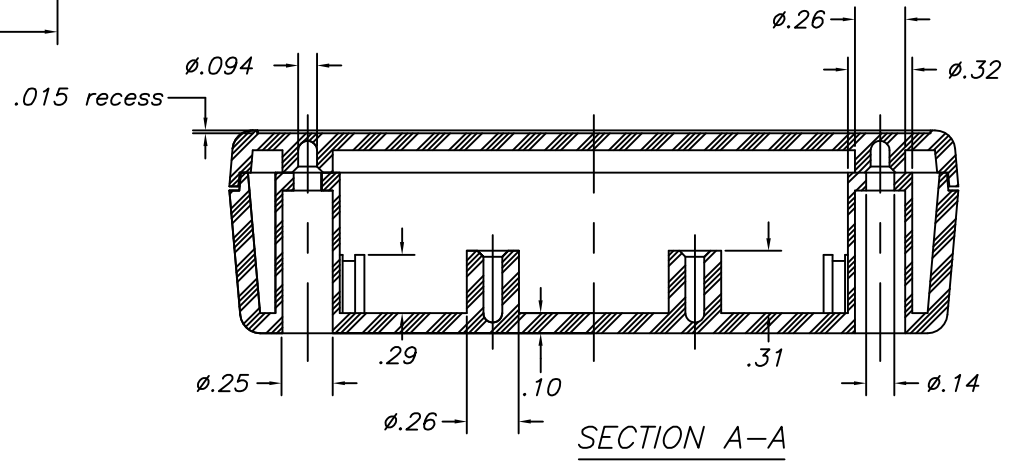
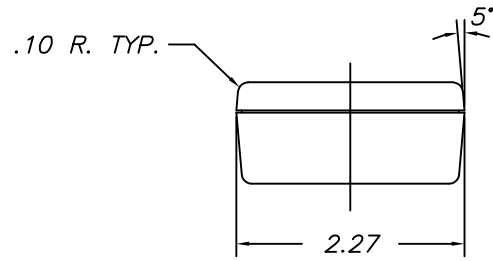
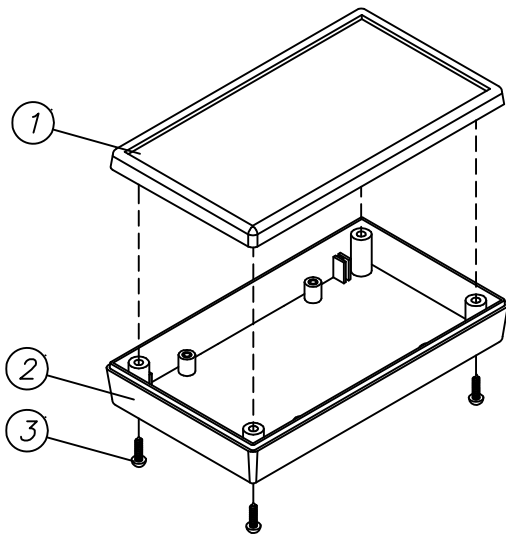
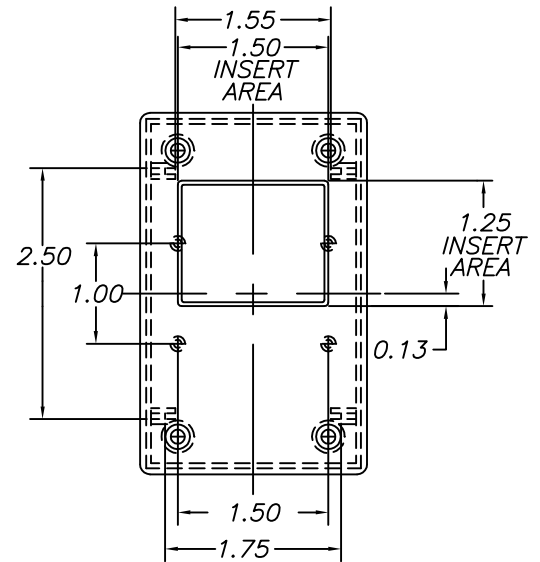
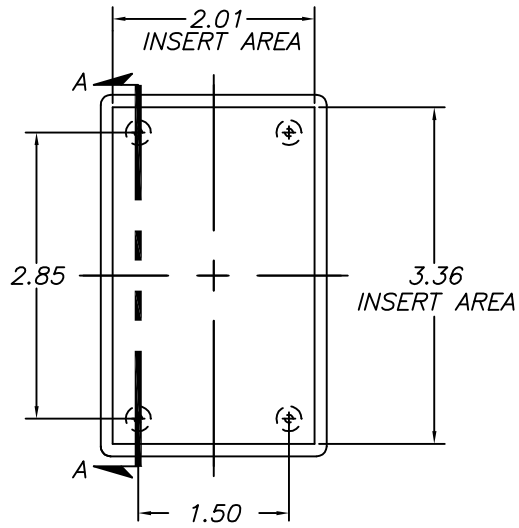
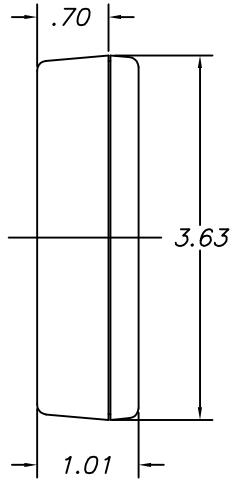

10-7-08.

ALL DIMENSIONS ± .010

ITEM	PART NO.	DESCRIPTION	ACCESSORIES	
			PART NO.	DESCRIPTION
1	10I	PLASTIC TOP	50	FEET
2	11	PLASTIC BOTTOM	310	PROTOTYPE GRID BOARD (HORIZ.)
3	6013	SCREWS (4)	410	PROTOTYPE CLAD BOARD (HORIZ.)
			PC	POCKET CLIP